

## AQS51/61-KAM COMBINED CO<sub>2</sub>-/TEMPERATURE DUCT SENSOR/CONTROLLER

### PRODUCT DATA

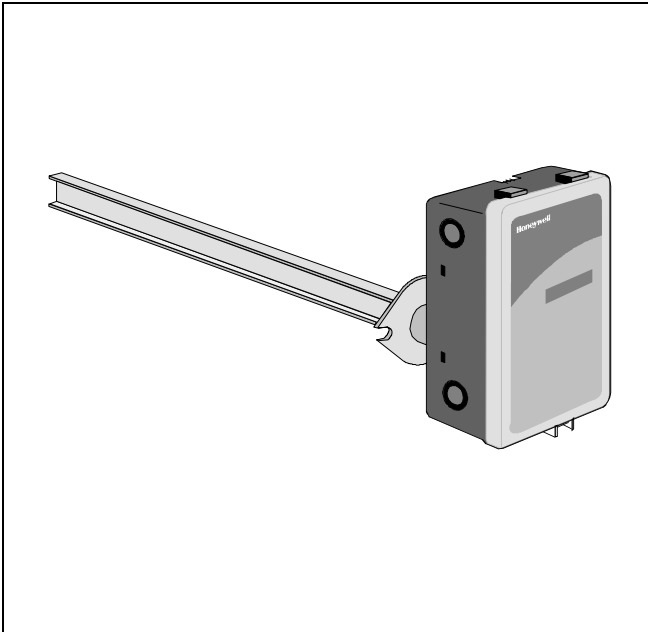

### GENERAL

The AQS51-KAM and AQS 61-KAM sensors/controllers for duct mounting measure the carbon dioxide (CO<sub>2</sub>) concentration and the temperature in the return or outside air. They are used in ventilation and air conditioning systems to control the amount of fresh outside air being supplied to the occupants for acceptable indoor air quality and to reduce unnecessary conditioning of outside air during low-occupancy periods.

This Demand Controlled Ventilation (DCV) is a cost effective solution to conserve energy and to ensure that the fresh outside air supplied is no more than is necessary to meet the actual requirements of the occupants at any given time.

The sensors/controllers offer separate 0(2)...10Vdc or 0(4)...20mA outputs for CO<sub>2</sub> and temperature and in addition a digital ON/OFF relay output with switching hysteresis for alarm or other purposes.

The UART interface (RS232) for serial communication allows a PC to be connected in order to perform maintenance checks or reconfigurations during normal operation. If used as a controller, each of these outputs can be configured to

provide a more complex ventilation strategy based on a mixture of CO<sub>2</sub> plus temperature measurements and to assign a number of functions, including hierarchy. For this analog output configuration, the software program STRATEGY is available, which is part of the User Interface Program Software package AQS-USP22 used for re-calibration, change of the measurement range or other service or set-up purposes.

The switching setpoint and differential of the relay output for CO<sub>2</sub> limit monitoring or plant/system ON/OFF control can be adjusted within the measurement range. This output can be used also as automatic fire threshold to switch off ventilation, when CO<sub>2</sub> levels exceed normal limit of e. g. 2500 ppm in case of fire.

### FEATURES

- CO<sub>2</sub> measurement range 0...3000 ppm corresponding to 0...0.3% CO<sub>2</sub>. Factory-calibrated 0...2000 ppm
- Multifunctional unit for temperature and CO<sub>2</sub>-measurement or control
- State-of-the-art Non-Dispersion-Infrared (NDIR) technology to measure carbon dioxide gas
- Automatic drift correction (ABC-algorithm) based on a long term evaluation provides typical zero drift check maintenance-intervals of up to 5 years
- Standard output signals 0(2)...10 Vdc or 0(4)...20 mA each for CO<sub>2</sub> and temperature measurement or control
- Programmable mixed controller signal output(s) provides ventilation control strategies to match exactly the application requirements
- Digital ON/OFF relay output for CO<sub>2</sub> limit monitoring
- RS232 interface for configuration, parameter setting or data exchange with a PC using Windows 95/98
- User interface program on diskette for service, recalibration and change of measurement ranges
- Optional with 4-digit LCD display with the selectable indication of:
  - CO<sub>2</sub> and room temperature alternating
  - Error code
  - CO<sub>2</sub>-concentration (ppm)
  - Temperature (°C)
  - Analog Output1
  - Analog Output2

## MODELS

Type	Order Number
CO <sub>2</sub> and Temperature Duct Sensor without LCD display	AQS51-KAM
CO <sub>2</sub> and Temperature Duct Sensor with 4-digit LCD display	AQS61-KAM

## ACCESSORIES

Description	Order Number
Service Software; 3.5" Diskette (for changing the sensing range, the parametrization and the post calibration)	AQS-USP22
Testset (consists of a portable gas generator for zero-position calibration, pump, packing, 3m tube, battery and transformer)	AQS-F0005
RS Cable with built-in electronics and adapters	AQS3/4 or AQS31/41

## TECHNICAL DATA

<b>General</b>	Power supply Power consumption Sensor life expectancy Maintenance interval Self diagnostics Status LED indication Power-up time Ambient operating limits - Temperature - Humidity	24Vac ± 20%; 50/60Hz or 24Vdc ± 20% 2W >15 years 5 years Complete power/sensor/analog outputs internal test Yellow = Maintenance required; Red = Relay activated ≤1 min 0...50°C 0...95%rh (non condensing)
<b>CO<sub>2</sub> - Measurement</b>	Operating principle Gas sampling mode Response time Measurement range Converting range Accuracy Pressure dependence Annual zero drift	Non-dispersive infrared (NDIR) Diffusion and Ø3 mm gas inlet push-on barb 2 min (diffusion) or 10 sec (0.2 ltr/min gas flow) 0...3000 ppm 0...2000 ppm = 0...10 Vdc (factory setting) or 2...10 Vdc / 0...20 mA / 4...20 mA ±1% of measurement range, ±5% of reading +1.58% of reading per kPa deviation from normal pressure 100 kPa < ±1% of measurement range
<b>Temperature Measurement</b>	Operating principle Measurement range Converting range Accuracy	Thermistor -10...60°C 0...50 °C = 0...10 Vdc (factory setting) or 2...10 Vdc / 0...20 mA / 4...20 mA ±0.2 K
<b>P+I control</b>	Settings and configuration with Service Software AQS-USP22 - Throttling range CO <sub>2</sub> - Throttling range temperature - Reset time adjustment ranges	100...800 ppm 1...10 K 2...500 sec (factory setting: 300 sec)

<b>Analog outputs</b>	Output signal	0...10 Vdc / 2...10 Vdc, impedance 100 Ω or 0...20 mA / 4...20 mA, load ≤500 Ω
	Resolution	10mV (10Bits)
	D/A conversion accuracy	±2% of output voltage, +0.1 V ±2% of output current, ±0.3 mA
	Protection	PTC fuse (auto reset), short-circuit proof
	Customization of P+I controller	Both outputs can be configured to any sensor mix (CO <sub>2</sub> + temperature + digital input of 5 proportional ranges with priorities and offsets, using the PC software STRATEGY, Version 3)
<b>Digital relay output</b>	Single pole, double throw (SPDT) switching, potential free contact. Factory adjusted switching setpoint and differential	1A/50 Vac (50VA) or 1 A / 24 Vdc (30 W)  Relay activated: ≥1000 ppm Relay deactivated: ≤900 ppm
<b>Dimensions</b>	Sensor housing Sampling probe	(84 x 142 x 46) mm 203 mm
<b>Zigzag traces (accessible after removing the cover)</b>  Shortage with a screwdriver simulates pushing of push button	MENU Zigzag traces	Toggles between the following 6 display modes on the 4-digit display: - CO <sub>2</sub> and temperature alternating - Error code - CO <sub>2</sub> in ppm - Temperature in °C - Analog output 1 - Analog output 2

## DIMENSIONS

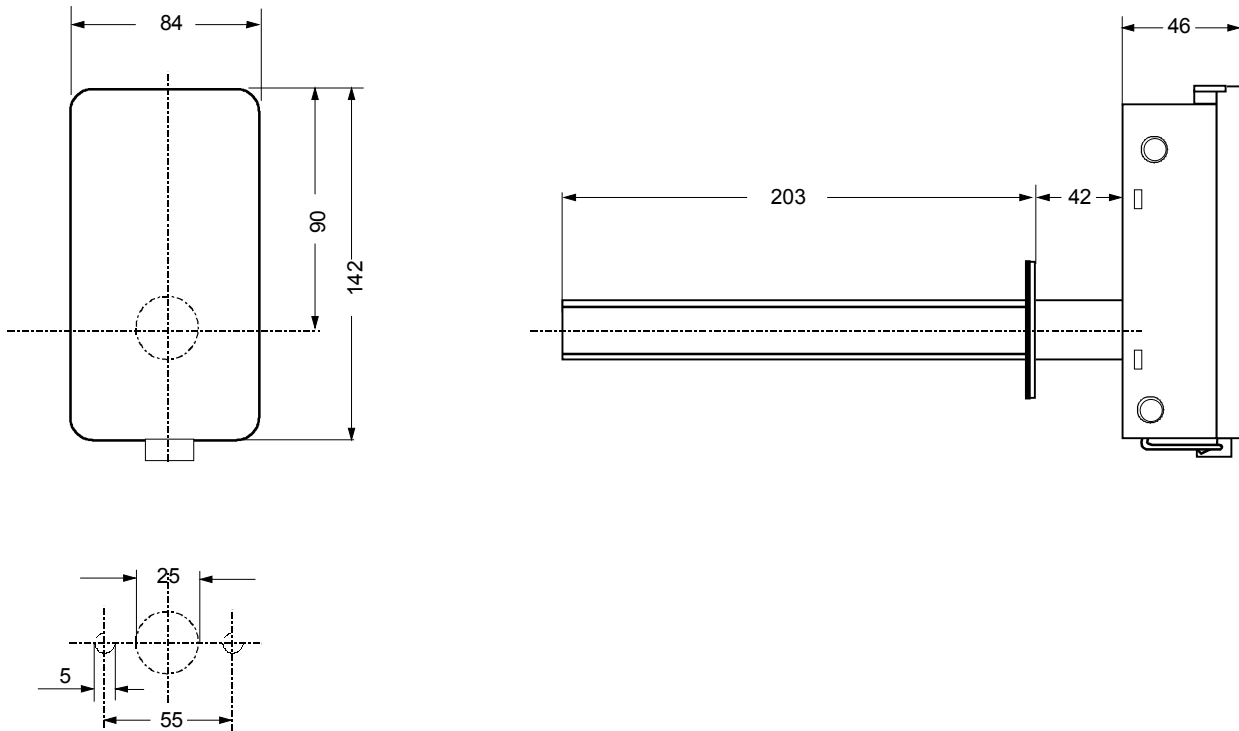

Fig. 1 Dimensions in mm

## OPERATION

### General

Each of these devices can be used as transmitter for measurement of CO<sub>2</sub> concentration and temperature or as a very flexible controller for proportional and integral control of mixed air dampers or variable speed controlled fans in stand alone applications.

The relay output can be used for CO<sub>2</sub> limit monitoring or plant/system ON/OFF control.

If used as a transmitter, it converts the actual measured values of the CO<sub>2</sub> concentration and temperature into standard output signals 0(2) to 10 Vdc or 0(4)...20 mA depending on the adjusted measurement ranges.

Directly connected to the analog inputs of Honeywell DDC systems it allows the required flexibility for a wide range of applications and the use of different demand controlled ventilation strategies to match exactly the requirements of the control system.

If used as a controller the actual measured values are compared with the programmed setpoints. Depending on the deviation the control output values are calculated and converted into two separate 0(2)...10Vdc or 0(4)...20mA outputs which can drive directly final control devices. The proportional band settings control the output spans.

In this application the AQS-USP22 software package can be used to configure the available two analog outputs for temperature and ventilation control, and to assign for each output a number of functions to provide different ventilation control strategies.

All sensor measurements can be addressed to these functions and mixed together by this software to form two independent and intelligent P+I controllers.

The relay output contact CM-NO is closed, if the CO<sub>2</sub> level exceeds the factory adjusted limit of 1000ppm and the contact CM-NC is closed, if the CO<sub>2</sub> level is equal or below 900ppm. These parameters are programmable within the specified measurement range.

### APPLICATION ADVICE

For rooms where are the occupants the source of the main air pollution, a CO<sub>2</sub> concentration of max. 1200ppm should not be exceeded.

### MOUNTING

The AQS51-KAM and AQS61-KAM sensor/controllers are supplied with the sensor printed circuit board already mounted into the aspiration box.

Mount the unit in the return or outside air duct in a position far away from external heat sources and where it is easy accessible for service and maintenance purposes.

Since there might be a substantial pressure difference between the duct and ambient air, it is indispensable that the sealings of the cable entry bushings, the cable feed through, the box cover and the duct entrance are absolutely tight to avoid ambient air from suction into the aspiration box. The duct entrance may need additional sealing paste in order to prevent leakage.

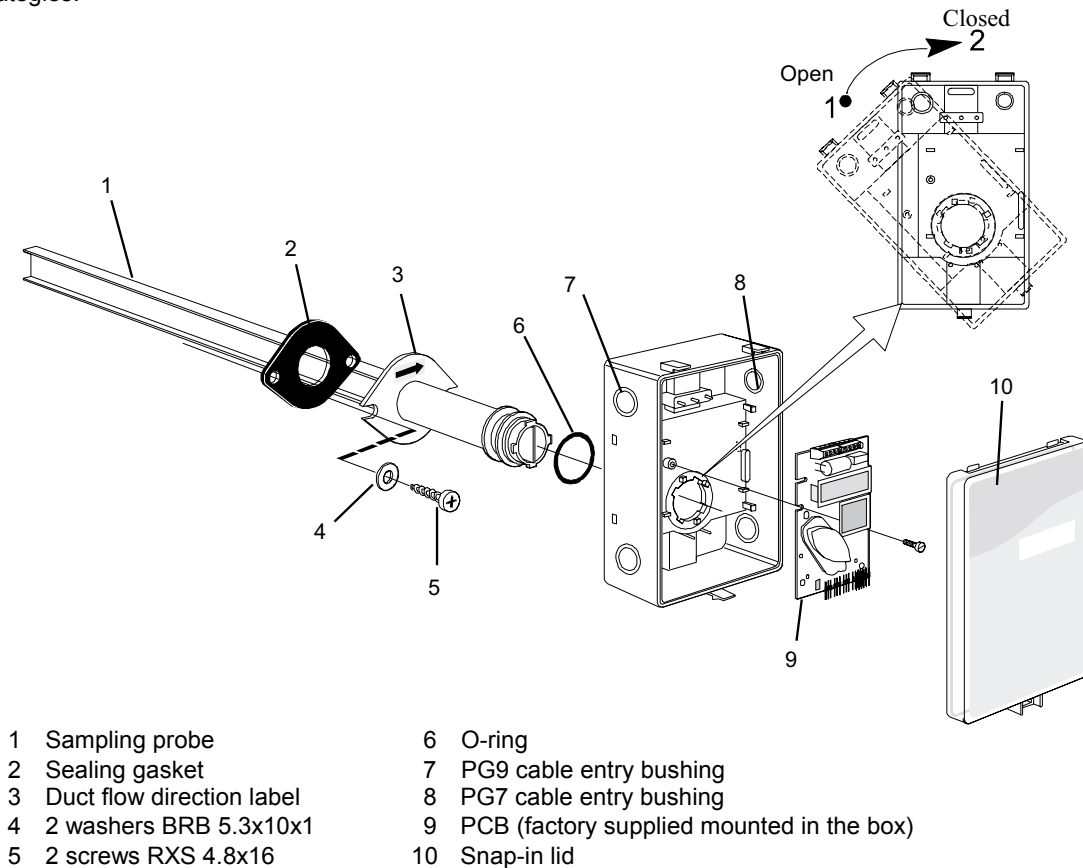

**Fig. 2 Parts list and mounting of the aspiration box to the sampling probe**

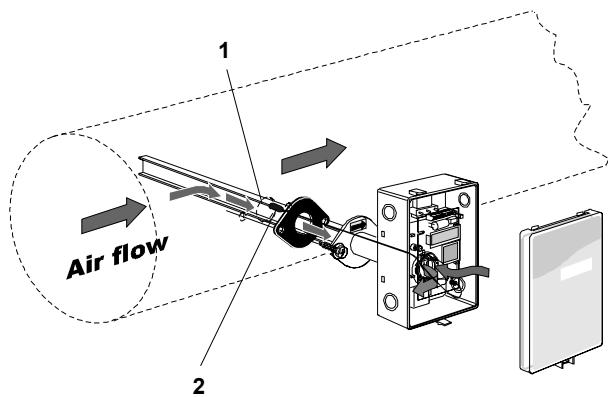

- 1 Hole with Ø25mm
- 2 Temperature sensor with 150mm cable

Fig. 3 Mounting of AQS51/61-KAM onto the duct

### Mounting Instructions

1. Drill a Ø25 mm hole for the sampling probe (Fig. 2, Pos.1) into the duct of the selected mounting area.
2. Use the gasket (Pos. 2) to mark on the duct surface the positions of the two holes for the mounting screws.
3. Drill Ø4mm holes for the mounting screws (Pos. 5).
4. Insert the sampling probe (with the gasket) into the duct. Position the probe relative to the duct so that the air inlet is on the left hand side and faces toward the duct air flow. For flow direction see also the arrow on the flow direction label (Pos. 3).

NOTE: In cases where the sampling probe can't be mounted with air flow direction from the left to the right, reversed flow direction through the sampling probe is possible, but influences the response time slightly. Use the enclosed arrow sticker to indicate on the probe the opposite and correct air flow direction

5. Fasten the sampling probe and the sealing gasket onto the duct with the two screws (Pos. 5).
6. Remove the cover of the aspiration box. The box has several knock outs in two dimensions for PG7 (Pos. 8) and PG9 (Pos. 7) cable entry bushings. To make a hole, insert a screwdriver into the groove and hit firmly. Mount for each cable a cable entry bushing into the aspiration box and seal properly.
7. Mounting the aspiration box to the sampling probe is performed by a snap-in bayonet fitting (Pos. 10). Insert first the temperature sensor placed on the end of a 150mm long soldered-on lead (Fig. 3, Pos. 2) into the air inlet to ensure accurate temperature measurement. Turn the box by approx. 23° ccw and stick the box onto the sampling probe, so that the probe is fitted into the notches of the box, then turn the box cw until stop (see Fig. 2).
8. Feed the cables through the cable entry bushings and seal the cable entries carefully by turning the nut to prevent ambient air suction into the aspiration box during operation. Feed never more than one cable through a cable entry bushing.

9. Select the required output ranges by setting the three coding jumpers accordingly to Table 1. The default settings are for 0...10Vdc outputs as indicated by the darker jumper positions in Fig. 5. The outputs have to be configured before the unit is connected to the power supply. Do not change jumper positions when power is on.
10. Connect the cable wires to the terminal block as listed in Table 2.

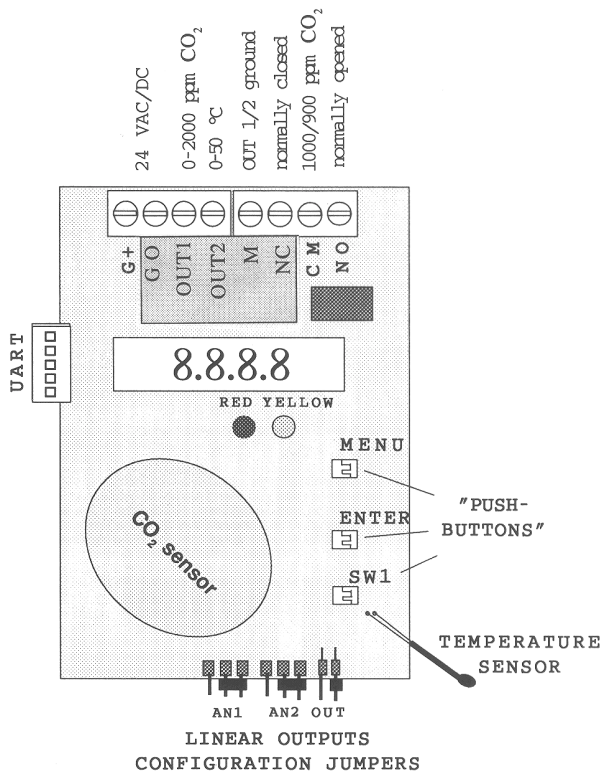

11. Mount the cover.

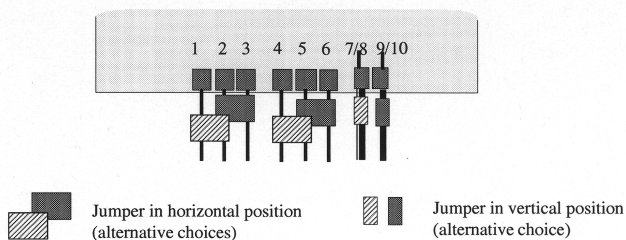

Fig. 4 Printed Circuit Board

Fig. 5 Jumper positions

Pin	Jumper	Marked	Function
1 2 3	AN1	Current Current/Voltage Voltage	Pin 1 and 2 provides 0(4)...20mA for OUT1 Pin 2 and 3 provides 0(2)...10Vdc for OUT1
4 5 6	AN2	Current Current/Voltage Voltage	Pin 4 and 5 provides 0(4)...20mA for OUT2 Pin 5 and 6 provides 0(2)...10Vdc for OUT2
7-8 9-10	OUT	20 - 100% 0 - 100%	Pin 7 and 8 provides 2...10Vdc or 4...20mA Pin 9 and 10 provides 0...10Vdc or 0...20mA

**Table 1 Jumper selections**

## WIRING

Connection Terminal	Function	Electrical Data	Remarks
G+	Power+	24Vac/dc+	Internal rectifying diode
G0	Power ground (-)	24Vac/dc-	(see Note 1!)
OUT1	Analogue output 1 (+)	0...10Vdc, 0...20mA, 2...10Vdc, 4...20mA	According to OUT, AN1 jumper positions
OUT2	Analogue output 2 (+)	0...10Vdc, 0...20mA, 2...10Vdc, 4...20mA	According to OUT, AN2 jumper positions
M	Signal ground (-)		Protected by PTC resistor
NC CM NO	Normally closed Common relay terminal Normally open	Potential free contact relay 1mA/5V up to 1A/50Vac/24Vdc	Triggered by register OUT3

**Table 2 Electrical terminal connections**

NOTE1: The ground terminal is used as negative power supply DC input or AC phase ground G0 (halfwave rectifier). The signal ground M, protected by a PTC resistor, is the same as power ground G0 (permitting a "3-wire" configuration). A single transformer may be used for the entire system. Situations can occur where different transformers must be used.

NOTE2: AQS51/61 can supply both a voltage or a current output for OUT1/OUT2. To change between voltage and current output mode the hardware jumpers have to be set in accordance. There is one jumper for AN1 and one for AN2, so that one output can be a voltage output and the other a current output. Both voltage output and current output can be 0...100% (0...10 Vdc or 0...20 mA) or 20...100% (2...10 Vdc or 4...20 mA) The same percentage are used for both outputs, see Table 1.

Wiring should be done only according to the actual job wiring diagrams or above wiring list. All wiring must conform to applicable codes, ordinances and regulations.

Electric discharge may damage the sensor electronics. Therefore handle the unit carefully and avoid electrostatic discharge.

Do not connect the power supply unless all other connections and settings are correctly done.

The AQS51/61 signal ground (M) is not galvanically separated from the power supply. If the analog output signals are connected to controllers or DDC system, the same

ground potential has to be used or install separate transformers for sensor and controller/DDC system.

## START UP

After connected to a 24Vac power supply, the unit is ready for operation.

1. Select on the AQS61-KAM the needed display indication by short-circuiting the MENU zigzag trace with a screwdriver, default setting is ppm and °C alternating.  
If operational parameters different from the standard values like converting range or special ventilation strategies are required, use a PC and the Service Software AQS-USP22 for this purpose.
2. Using the ABC-function, recalibration of the unit is required only after 5 years of operation.

## OPERATION MODE AQS61-KAM

This sensor has two zigzag traces, MENU and ENTER, on the printed circuit board (see Fig. 4), which are only accessible after removing the cover.

The zigzag trace MENU is available for selection of the indicated value. The function is as follows:

Zigzag Trace	Function/Remarks
<b>MENU</b>	Display selector – Short-circuiting of the MENU zigzag trace toggles between the following indication sequence (rotation principle): <ol style="list-style-type: none"> <li>1. °C and ppm alternating</li> <li>2. Error code</li> <li>3. CO<sub>2</sub> - concentration in ppm</li> <li>4. Temperature in °C</li> <li>5. OUT1 value % full scale</li> <li>6. OUT2 value % full scale</li> </ol>

Another option is to indicate that the analog output control range has been exceeded, any or both outputs have reached 100% output value.
---

To access the maintenance level short at level 5.(OUT1 value) ENTER-MENU- ENTER in sequence. The maintenance mode is restricted to competent trained service personnel only. For detailed information see the Service & Checkout Instruction EN2B-0461GE02.

## LED - Signals

The standard sensor has two different LED's, yellow and red located below the semi-transparent LCD display. The LED's indicate the status of the device as shown in the table below.

LED	Function/Remarks
<b>yellow</b>	Maintenance LED - Steady ON in cases, if an error flag is set. On the AQS61-KAM this is indicated in addition on the display by a wrench icon. By connecting a PC to the serial port or selection of the error code display mode on the AQS61-KAM the source of the problem can be defined (see error code list).
<b>red</b>	Relay Status LED - Steady ON, if relay is activated (contact CM-NC open, CM-NO closed). If the relay output is not used for any control purpose, its trigger point can be programmed for other tasks, e. g. indication by the red LED of dangerous gas level has been reached.

## SELF DIAGNOSTICS

The system contains complete self diagnostics, which is executed automatically every time the power is turned on. This function checks returns an error byte to system RAM. If the error message equals 8, it will not be cleared until a new self diagnostic procedure is activated after a power up. The other codes are reset when the causes have vanished.

For AQS51/61-KAM the tests comprise checking internal voltage regulators and output values. In addition, constantly during operation, the sensor probes are checked against failure by checking the valid dynamic measurement ranges.

## Error Code and Actions

Error Code	Suggested Action
4	Indicate problems with the power supply. <b>Check power supply voltage.</b>
8	Indicates problem with OUT1. Could be too high an output load connected to the output. Check OUT1 with a voltmeter and compare the output with the LCD reading (for AQS61-KAM). <b>Disconnect the output wiring</b> to check if the external load is too high and causes the error indication. To start the internal output diagnostic, switch the power off and restart the unit.
32	Sensor out of range. Occurs during over exposure of CO <sub>2</sub> sensor, in which case the error code will automatically reset when the measurement values return to normal. Could also indicate the need of zero point calibration. If the CO <sub>2</sub> reading is correct and the error code remains, the temperature sensor must be broken.
NOTE:	If several errors are detected at the same time, the different error code numbers will be added together into one single error code.

# Honeywell

### Home and Building Control

Honeywell AG  
Böblinger Straße 17  
D-71101 Schönaich  
Germany  
<http://europe.hbc.honeywell.com>

Subject to change without notice. Printed in Germany

EN0B-1023 GE02R0700

Manufacturing location is certified according to 