

CDS2000 SERIES

CO₂ GAS DETECTOR

PRODUCT SPECIFICATION SHEET



FEATURES

- High sensitivity and good resolution
- High technology adopted by NDIR method
- No calibration needed in installation
- No maintenance needed in normal applications
- Two type signal(DCV and DCA) output
- Easy installation
- Compact size (70mm×122mm×32mm)

APPLICATION

CDS2000A1000 is IAQ(Indoor Air Quality) sensor, which has been designed to detect carbon dioxide gas in the air. This model has resolution by NDIR method, so it is an optimum device for ventilation of buildings, houses, etc. Also, the advantage of this model is compact size and easy installation.

Contents

Application	1
Features	1
Specification	
1	2
Dimensions	2
Installation	2
Assembly	2
Wiring Diagram	3
Cautions on Use	

SPECIFICATION

Model	Gas Detected	Sensing Range	Wiring
CDS2000A1000	Carbon Dioxide (CO ₂)	0 ~ 2,000 ppm	4 wire

Gas detected	: Carbon dioxide (CO ₂)
Sensing method	: NDIR(Non-dispersive infrared)
Detect range	: 0~2,000ppm
Accuracy	: ± 30ppm ±5% of measured value
Warm-up time	: Within 2 minutes
Power supply	: 24Vac, 24Vdc±20%, 50/60Hz
Output signal	: 0~10Vdc or 0~20mA
Response time	: Within 150 sec (90%)
Wiring	: 4-wire
Operating temp.	: 0 ~ 50℃
Operating Humi.	: 0 ~ 95%RH (non condensing)
Storage temp.	: -20 ~ 60℃
Storage Humi.	: 0 ~ 95%RH (non condensing)

→Current output (0~20mA) : set jumper (JPI) on top of the PCB to "I" (refer to the output selection method figure)

3. Installation procedure

- ① Connect power and signal output wires to the terminal block at the base side of device. Then, verify the lines correctly fixed to the terminal (refer to the wiring method figure & assembly figure)
- ② Push the bottom of front cover to separate from the base (refer to the assembly figure)
- ③ Make sure to distinguish the upper and lower sides of the base and fix the base by using the screw nails (be cautious PCB assembly not to be damaged)
- ④ Reassemble the cover.

4. Recommended installation location

- ① Mount approximately 120~180cm above the floor
- ② Avoid the following places to install
 - A place within 1m of the gate or window
 - A place near a ventilation system in which in directly affects the flow of the air
 - A place within 1m of a corner where two walls are attached
 - A place which is likely to be influenced by breath
- ③ If sudden movement of the device from cold place to warm place makes it dewy, make sure to dry it enough before using again.
- ④ When installing, power and output wires must keep enough distance with other utility power lines for safety

DIMENSIONS

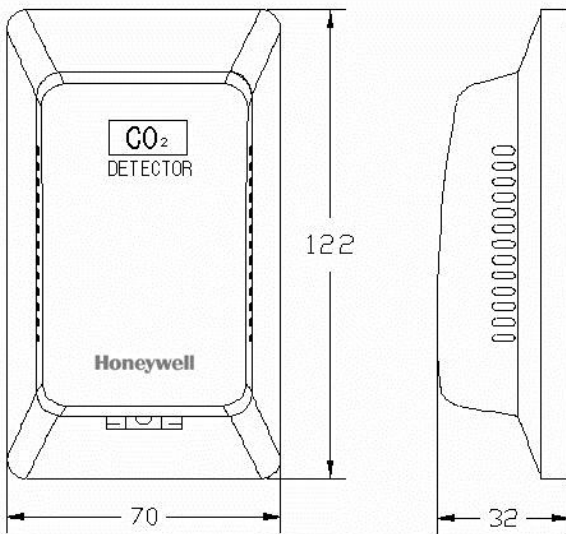

Fig. 1 CDS2000A1000 dimensions (mm)

INSTALLATION

1. Confirm the product model number on the package box and check wiring method (refer wiring method figure).
2. Output mode change
 - Initially, output mode is configured as 0~10Vdc
 - Voltage output (0~10Vdc):set Jumper(JPI) on top of the PCB to "V" position (refer to the output selection method figure)

ASSEMBLY

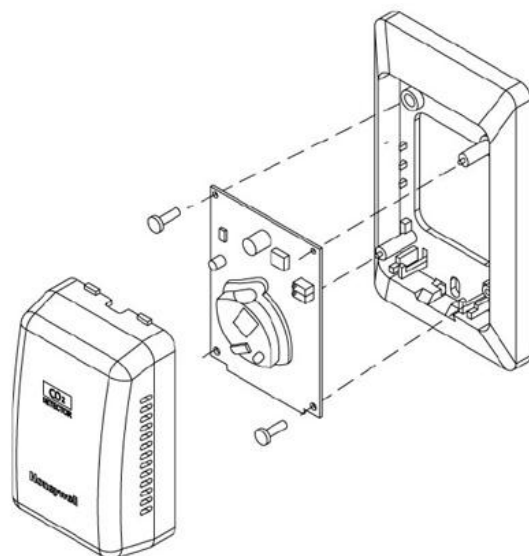

Fig. 2 CDS2000A1000

WIRING DIAGRAM

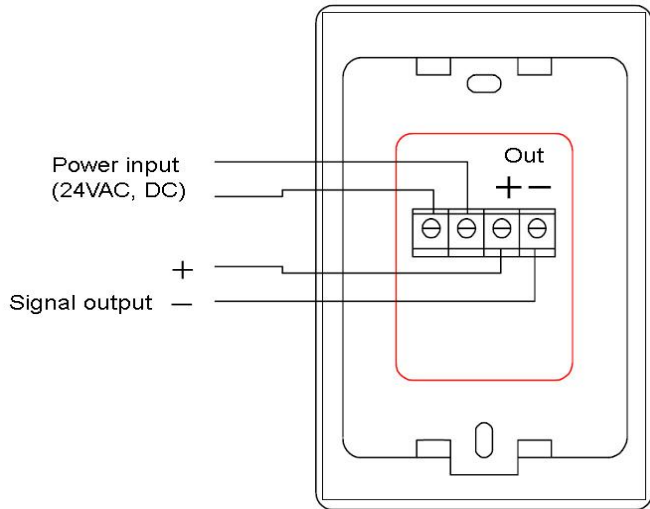

Fig. 3 CDS2000A1000 wiring

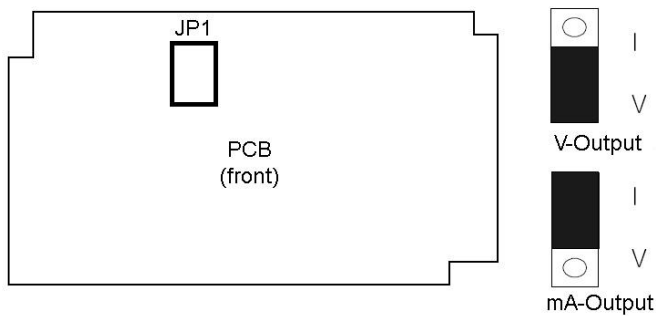

Fig. 4 CDS2000A1000 output selection method(JP1)

CAUTIONS ON USE

- Do not use this device for outdoor use. This product is manufactured only for indoor use.
- This device must abide by the operating temperature/humidity and the storage temperature/humidity.
- Do not leave or use the device for longtime in a highly damped place in which humidity is near 95%RH.
- The standard test condition in which the product was tested is $25^{\circ}\text{C} \pm 3^{\circ}\text{C}$, $50^{\circ}\text{C} \pm 30\% \text{RH}$. Signal may vary slightly by environment condition.
- Be careful when install and use as vibration/shock/falling can cause a serious damage on the sensor.
- We do not guarantee the performance of the device in case of user installation, disassembling and inspection is necessary, please contact our technicians.
- Sensor using NDIR is influenced by air pressure. It can be used without correction within 300M above the sea level. However, add the output value by +1.0% per 100M height above 300M.
- Ex) If the output signal is indicating 600ppm at the height of 500M, correct the output to 630ppm by adding $30(600 \times 0.01 \times 5) \text{ppm}$.
- Do not use it for medical, lift or safety purpose.
- Use when it is fixed, but not use while it is in motion.

HONEYWELL

Honeywell Co., Ltd.

Environmental & Combustion Controls
18F, Kukje Center Building 191, Hangangro-2ga,
Yongsan-gu, Seoul, 140-702, Korea
Tel. 82-2-799-6170/6008
Fax. 82-2-749-6119/792-9013