

ML7420A/ML7425A,B

Electric Linear Valve Actuator

SPECIFICATION DATA

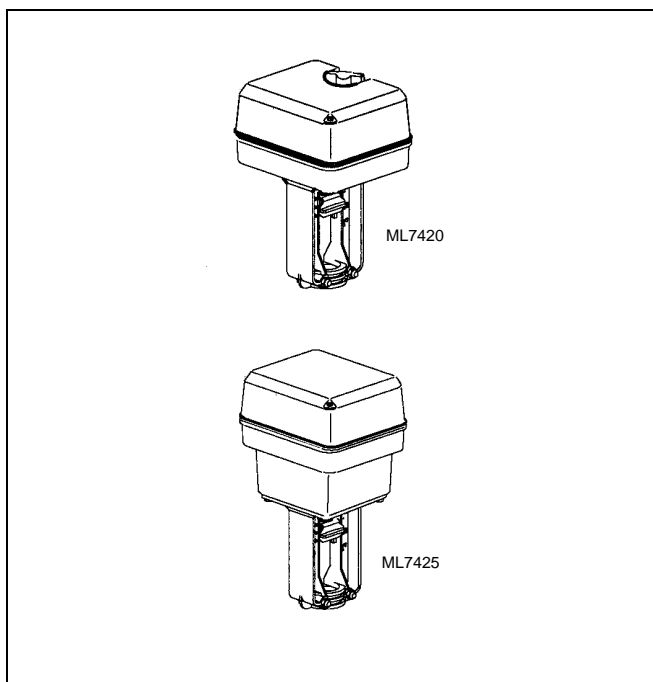

GENERAL

The ML7420A / ML7425A,B actuators are for modulating control with controls providing an analog output of 0 to 10Vdc or 2 to 10Vdc. They operate Honeywell's standard valves in heating, ventilation and air conditioning (HVAC) applications. The direction of movement is reversible by means of an internal selector plug.

FEATURES

- Easy and quick installation
- No separate linkage required
- No adjustments
- Low power consumption
- Force limiting end switches
- Spring return models
- Manual operator
- 0 to 10Vdc or 2 to 10Vdc signal input
- Position feedback signal
- Synchronous motor
- Direct / reverse action
- Stroke position on signal failure selectable
- Corrosion resistant design
- Maintenance free

SPECIFICATIONS

Temperature Limits

Ambient operating limits	-10 to +50°C @ 5 to 95%rh
Ambient storage limits	-40 to +70°C @ 5 to 95%rh
Medium valve temperature	Max. 150°C

Signals

Signal input voltage	y = 0 to 10Vdc or 2 to 10Vdc R _i = 100kΩ
Signal source output resistance	1kΩ max.
Position feedback signal	x = 2 to 10Vdc
Load	1mA max.

Safety

Protection class	II in acc. with EN60730-1
Protection standard	IP54 in acc. with EN60529
Flame retardant housing	V0 in acc. with UL94 (with metal cable gland)

This product meets the requirements of **CE**

Wiring

Wiring terminals	1.5mm ²
Cable entry	PG13.5. Two additional knock outs PG11 and PG13.5 for auxiliary switch and potentiometer accessories

Weight

non spring return type	1.3kg
spring return type	2.4kg

Material

Cover	ABS-FR
Base	glass fibre reinforced plastic
Yoke	aluminium diecast

Model Number	ML7420A3006	ML7420A3014	ML7425A3005	ML7425B3004
Supply Voltage	24Vac +/-15% 50/60Hz			
Power Consumption	5VA	7VA	12VA	
Signal Input 0(2)Vdc	Actuator stem retracted. Two way valve:"open", three way valve port A-AB:"closed" *			
Signal Input 10Vdc	Actuator stem extended. Two way valve:"closed", Three way valve port A-AB:"open" *			
Stroke	20mm			
Run Time @ 50Hz	1min	0.5min	1.8min	
Close-off Force	≥ 600N			
Spring Return Time	—		≈12s	
Spring Return Direction	—		Actuator stem extends at power failure	Actuator stem retracts at power failure

* Factory setting; can be reversed by action selector plug W3

OPERATION

General

The drive of a synchronous motor is converted into linear motion of the actuator stem by using a spur gear transmission. The actuator stem is connected with the valve stem by a button keyed retainer connection.

An integrated spring package limits the stem force to a factory adjusted value in either direction.

Installed microswitches switch off the actuator precisely when the specified stem force is reached.

Manual Operation

Actuators without spring return are equipped with a manual operator used in case of power failure. Manual operation is only possible after the power supply is switched off or disconnected.

To operate push the manual operator knob down and turn clockwise to move the stem downward and counter-clockwise to move the stem upward. If the actuator returns to automatic control, the manual operator knob unlocks automatically.

On actuators with spring return the manual operator is located under the cover.

Spring Return

The ML7425A,B spring return types provide a defined safety position of the valve in case of power failure.

The spring return actuators are shipped from the factory with a shipment stop (to lock the knob) in order to allow connection of the stem button retainer to the valve stem without power supply.

Electrical Installation

The actuators are delivered with a pre-installed cable gland PG13.5 and two additional knock outs for PG11 and PG13.5. Cable length/diameter for field mounting:

- Max. 200m/1.5mm² or 100m/1.5mm² (ML7420A3014)

NOTE

To avoid malfunction it is necessary to connect 24Vac power and ground (see Fig. 2).

NOTE

In case of replacement please note that the override switch has been changed (see Fig. 2).

Input Signal Failure

By means of selector plug W1* the actuator can be selected such, that in case of a signal input failure, (e.g. a broken wire) the actuator will run to one of the three positions:

- 0%: actuator stem position for 0(2)Vdc
- 50%: actuator stem in central position
- 100%: actuator stem position for 10Vdc

W1 is set by the factory to 50%.

Input Signal Range

The range of the analog input signal Y can be changed by changing the position of selector plug W2*

Action

The direction of action can be changed by repositioning of selector plug W3*. It is set by the factory such that the stem extends at increasing signal and retracts at decreasing signal.

NOTE

*Jumper plugs W1, W2 and W3 are accessible after the cover has been removed. They are located on the rear side of the protection sheet of the printed circuit board (see EN1C-0073 and EN1C-0074).

Output Signal "POSITION"

An analog output signal 2 to 10Vdc "POSITION" is available which represents the actual actuator position. It can be used for remote indication.

When the actuator stem is extended the output signal is 10Vdc.

Accessories

Auxiliary switches

The actuators can be equipped on site with an auxiliary switch unit with two switches. Their switching points are adjustable over the full length of the actuator stroke. The switches can be used to switch pumps or provide remote indication of any stroke position.

A cable gland PG13.5 is delivered with the unit.

Part number: 43191680-005

Auxiliary potentiometer

Auxiliary potentiometers are available for mounting on site. They can be used as feedback potentiometer and or to provide remote indication to the valve position. A cable gland PG13.5 is delivered with the unit.

Part number: 43191679-011 (10kΩ)

Part number: 43191679-012 (220Ω)

High Temperature Kit

(for applications >150°C medium temperature)

High Temperature Kit, Order Number	Valve	DN
43196000-001	V5011A/V5011K	15 - 40
	V5013A/V5013G	15 - 40
	V5011R/V5013R	15 - 50
	V5328A/V5329A	15 - 32
43196000-002	V5011A	50
	V5013A/V5013G	50
	V5328A/V5329A	40 - 80
	V5049A	15 - 65
	V5050A	15 - 80

CLOSE-OFF PRESSURE RATINGS in kPa

Stem Force	600N								
Stroke	20mm								
Valve Size	mm	15	20	25	32	40	50	65	80
	inch	1/2	3/4	1	1 1/4	1 1/2	2	2 1/2	3
Valves	Close-Off Pressure Ratings								
V5011R	1600	1600	1000	700	460	260			
V5011K	1600	1600	1300	1000					
V5013R	1600	1600	1000	700	460	260			
V5328A	1600/1000	1000	1000	600	350	200	120	50	
V5329A (PN16)	1000	1000	1000	790	480	260	160	100	
V5329C (PN6)	600	600	600	600	480	260	160	100	
V5049A	1600/1000	1000	1000	600	350	200	120		
V5050A	1000	1000	1000	600	350	200	120	50	
V5095A		1600	1600	1600	1600	1600	1600	1600	1600

For specific data of above valves see Specification Data No.:

V5011R	EN0B-064
V5011K	EN0C-0560
V5013R	EN0B-065
V5328A	EN0C-0432
V5329A,C	EN0C-0434
V5049A	EN0C-0433
V5050A	EN0C-0435
V5095A	EN0C-0490

DIMENSIONS

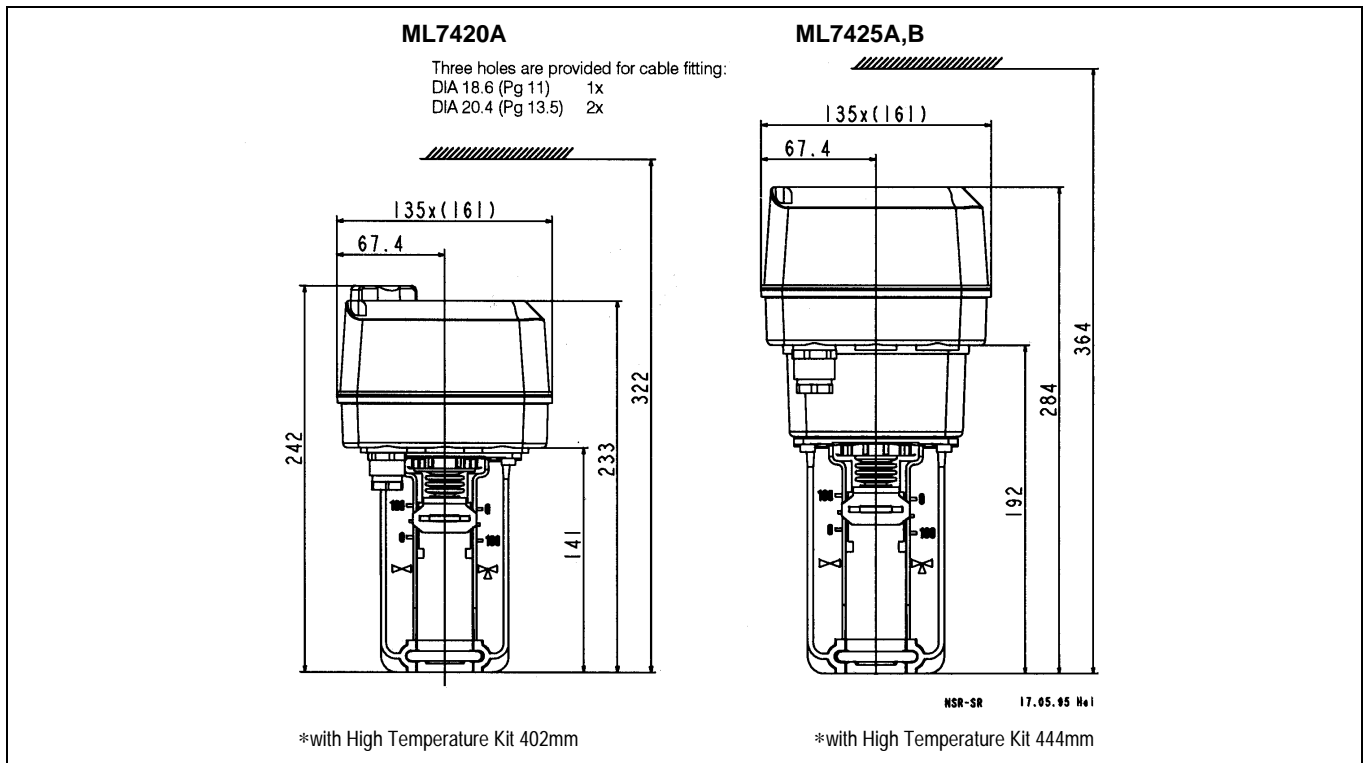

Fig. 1 Dimensions in mm

WIRING

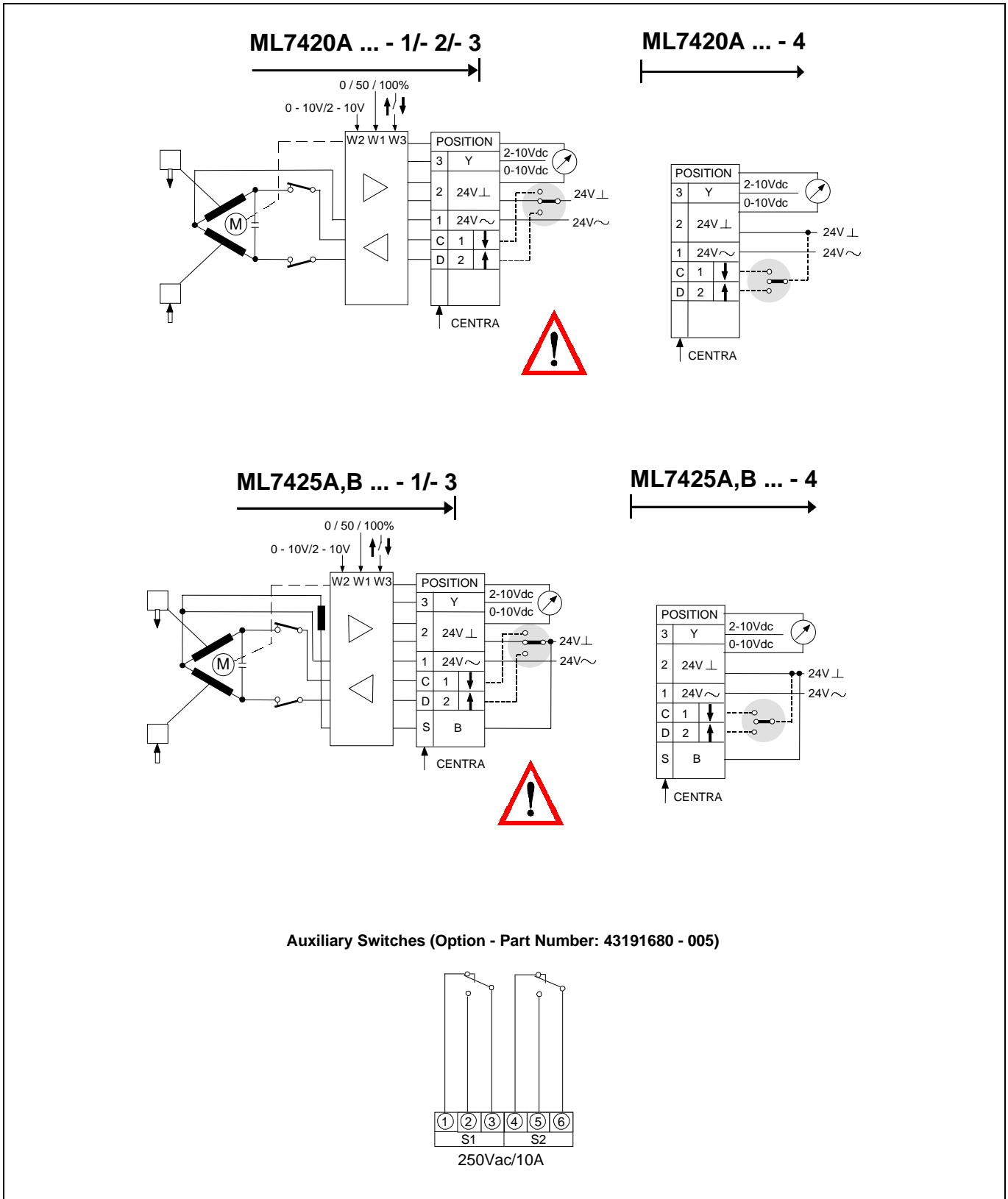

Fig. 2 Wiring

Honeywell

Honeywell Regelsysteme GmbH

Honeywellstr. 2-6

D-63477 Maintal

Tel. (0 61 81) 401-1

Fax (0 61 81) 401-400

Subject to change without notice. Printed in Germany

EN0B-0624GE02 R0399

Manufacturing location is certified according to 